

Harbour



OR-TUB-HARBOUR6835-X

SIZE:
67.5" x 35.5" x 22"

WATER CAPACITY:
114 Gallons

WEIGHT:
345 Pounds

BACK SLOPE:
11°

MATERIAL:
1-2" Nominal Thickness
Stonite™ Construction

FINISH:
Matte, Gloss

WARRANTY:
10 Year Warranty.

- FEATURES:**
- Integral waste and overflow included.
 - Overflow and drain comes standard in color match to tub, unless specified otherwise.
 - Bathtub available in 16 different color choices

OPTIONAL:

- Air System

- Blower and Control Panel Must be Remotely Located

- Electrical Requirements 1 15 AMP dedicated GF-115 Volts

- Comes with AeroClean™.
A revolutionary feature that creates an anti-bacterial environment in your bath and plumbing system.

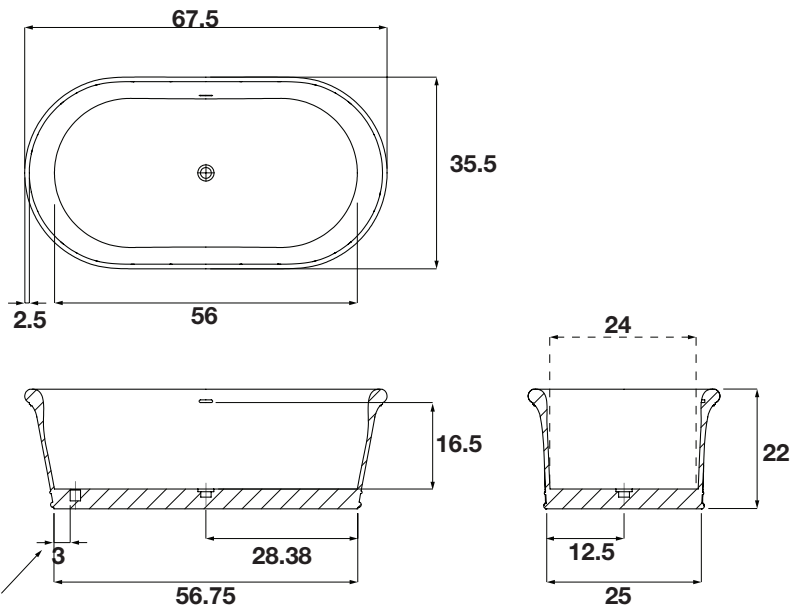

AIR INLET



CODES AND COMPLIANCES

Massachusetts code File no: P1-0614-491



All specifications and options subject to change without notice please contact a Renaissance Tile & Bath representative for more information.