

LULL

O|R

OR-TUB-LULL5831-X

SIZE:
58" x 31" x 21.5"

WATER CAPACITY:
65 Gallons

WEIGHT:
260 Pounds

BACK SLOPE:
28°

MATERIAL:
1-2" Nominal Thickness
Stonite™ Construction

FINISH:
Matte, Gloss

WARRANTY:
10 Year Warranty.

- FEATURES:**
- Integral waste and overflow included.
 - Overflow and drain comes standard in color match to tub, unless specified otherwise.
 - Bathtub available in 16 different color choices

OPTIONAL:

- Air System

- Blower and Control Panel Must be Remotely Located
- Electrical Requirements 1 15 AMP dedicated GF-115 Volts
- Comes with AeroClean™. A revolutionary feature that creates an anti-bacterial environment in your bath and plumbing system.

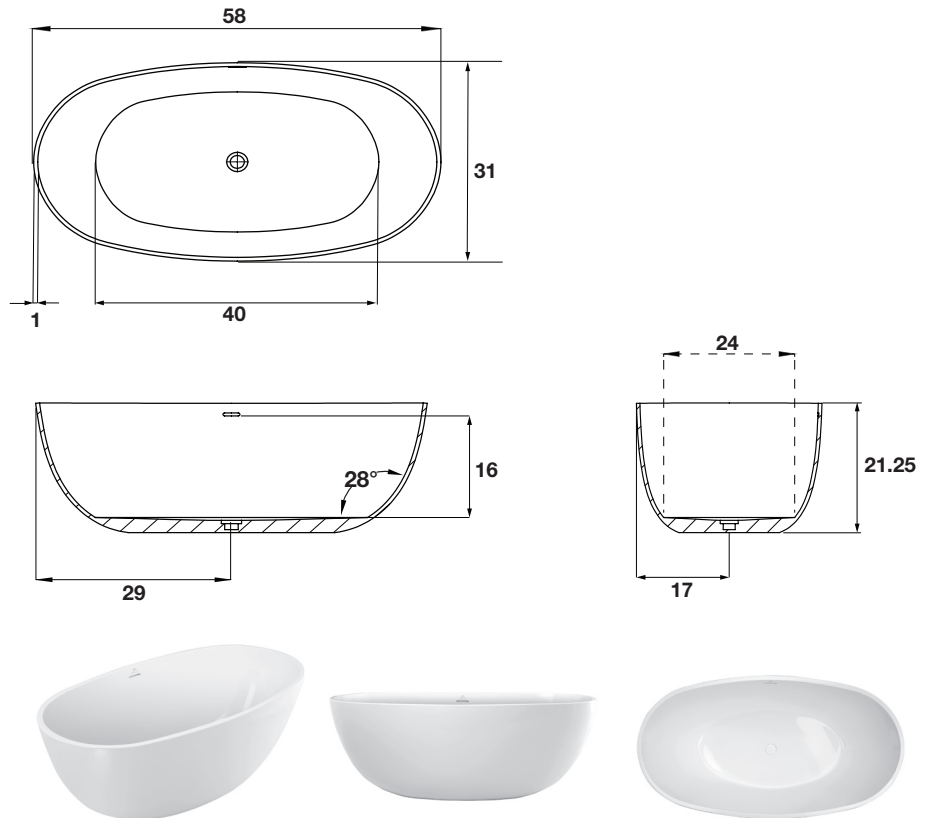

CODES AND COMPLIANCES
Massachusetts code File no: P1-0614-491



All specifications and options subject to change without notice please contact a Renaissance Tile & Bath representative for more information.

LULL

O|R

OR-TUB-LULL6634-X

SIZE:
66" x 34" x 21.5"

WATER CAPACITY:
65 Gallons

WEIGHT:
350 Pounds

BACK SLOPE:
28°

MATERIAL:
1-2" Nominal Thickness
Stonite™ Construction

FINISH:
Matte, Gloss

WARRANTY:
10 Year Warranty.

- FEATURES:**
- Integral waste and overflow included.
 - Overflow and drain comes standard in color match to tub, unless specified otherwise.
 - Bathtub available in 16 different color choices

OPTIONAL:

- Air System

- Blower and Control Panel Must be Remotely Located
- Electrical Requirements 1 15 AMP dedicated GF-115 Volts
- Comes with AeroClean™. A revolutionary feature that creates an anti-bacterial environment in your bath and plumbing system.

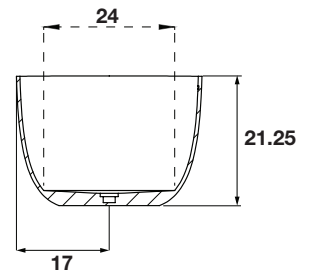
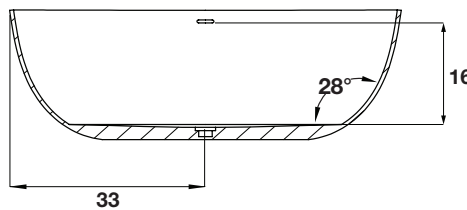
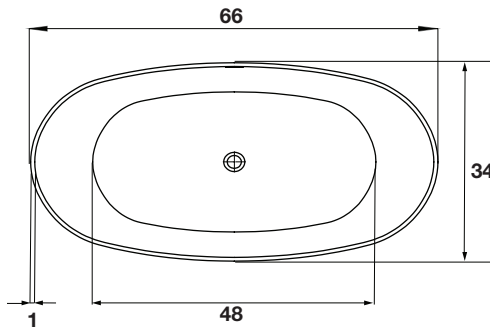

CODES AND COMPLIANCES
Massachusetts code File no: P1-0614-491



All specifications and options subject to change without notice please contact a Renaissance Tile & Bath representative for more information.

LULL

O|R

OR-TUB-LULL7034-X

SIZE:
70" x 34" x 21.5"

WATER CAPACITY:
65 Gallons

WEIGHT:
350 Pounds

BACK SLOPE:
28°

MATERIAL:
1-2" Nominal Thickness
Stonite™ Construction

FINISH:
Matte, Gloss

WARRANTY:
10 Year Warranty.

- FEATURES:**
- Integral waste and overflow included.
 - Overflow and drain comes standard in color match to tub, unless specified otherwise.
 - Bathtub available in 16 different color choices

OPTIONAL:

- Air System

- Blower and Control Panel Must be Remotely Located
- Electrical Requirements 1 15 AMP dedicated GF-115 Volts
- Comes with AeroClean™. A revolutionary feature that creates an anti-bacterial environment in your bath and plumbing system.

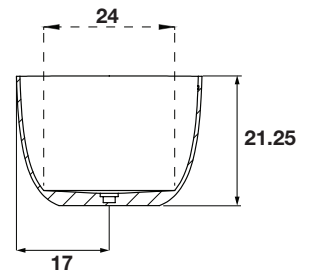
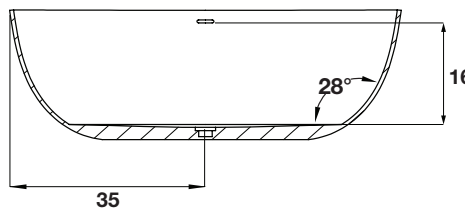
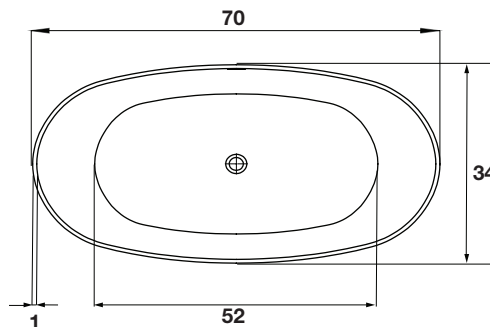

CODES AND COMPLIANCES
Massachusetts code File no: P1-0614-491



All specifications and options subject to change without notice please contact a Renaissance Tile & Bath representative for more information.